

Antenna Installation Guide

RV / Trucker
Spring Mount
Cellular Antenna

#301133
KIT# 308433



Features:

- Multi-Band (700/800/900/1900 MHz)
- Analog and digital
- Improves voice and data signal quality
- Designed for RV's
- Built-in spring reduces impact damage
- Built-in ground plane allows for mounting on any surface

How it Works

Wilson Electronics RV / Trucker Spring-Mount Cellular Antenna will collect the cell tower signal and send it through the cable to a Signal Booster or directly to the cell phone or laptop data card. When the cell phone or data card transmits, the signal is transferred to a Signal Booster or directly to the antenna and transmitted back to the cell tower.

Antenna Adapter Required (Sold Separately)

A phone/data card-specific, Antenna Adapter is required when connecting the antenna directly to a cell phone. To identify the correct adapter, see Wilson Electronics Adapter Guide at www.WilsonElectronics.com or contact Technical Support at 866-294-1660.

RV Package

- 1 - RV / Trucker Antenna
- 6 - Radials (3 short, 3 long)
- 1 - Thread-locker liquid
- 1 - 3-way mount (included in kit #308433)

Installing the Antenna

1. Select a suitable location to install the antenna on your RV, as high on the vehicle as possible and at least 12 inches away from any other antenna. For best results, use Wilson Electronics 3-Way Mount (#901104). This bracket will enable you to mount the antenna on a mirror or attach it to the side of your RV.
2. If you are installing on a mirror, clamp the mount to the mirror support and tighten the four nuts and bolts. If you are mounting directly to the side of your RV, remove the nuts, bolts and the smaller half of the mount and use the four holes in the larger half to attach it flush to the side of the RV, using screws or bolts, nuts and washers appropriate for your particular installation. In both cases, be sure the flat mounting base of the mount is positioned up.

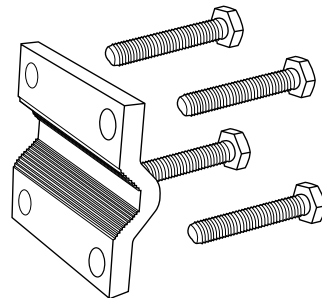
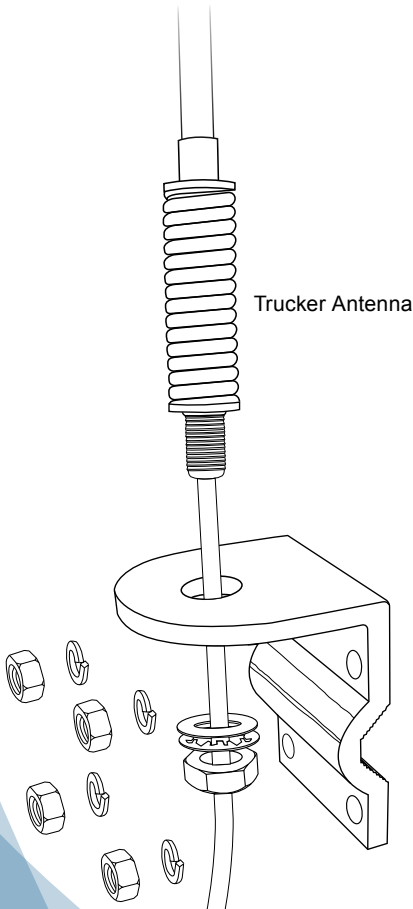

3-Way Mount

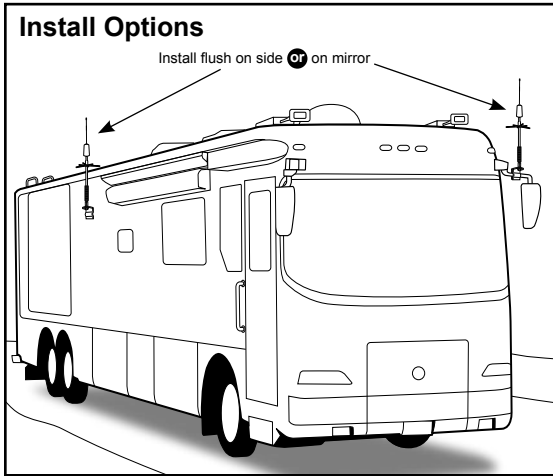

3. Screw the six antenna radials into the holes under the plastic coil housing on the antenna. The included thread-locker liquid must be used to ensure the radials do not vibrate loose. Tighten the radials snugly with a wrench.

4. Loosen the jam nut at the base of your antenna. Remove it, along with the star washer and the flat washer.

5. Thread the cable down through the hole in the flat mounting base until the antenna is positioned vertically on the base. Then thread the flat washer, star

washer and jam nut (in that order) back onto the cable and up to the threaded base of the antenna. Tighten the jam nut to the underside of the mounting base with a wrench.
CAUTION: Do not over-tighten.

6. Route the cable from the antenna to the location where you will be using your phone or data card. Extension cables up to 10 feet in length are available through your dealer.

7a. To connect directly to a cell phone or data card:

- Connect the antenna cable to the connector on the adapter (sold separately).
- Connect the adapter to your cell phone or data card.

7b. To connect to a Wilson Electronics Direct Connect Signal Booster (sold separately):

- Using the included cable wrench, connect the antenna cable to the side of the Signal Booster labeled "Outside Antenna."
- Connect the adapter extension cable to the side of the Signal Booster labeled "Cellular Phone."
- Connect the adapter extension cable to the adapter.
- Connect the adapter to your cell phone or data card.

7c. To connect to a Wilson Electronics Mobile Wireless Signal Booster (sold separately):

- Using the included cable wrench, connect the antenna cable to the side of the Signal Booster labeled "Outside Antenna."

Warning: If using a Signal Booster, ensure that all antenna and adapter cables are connected before powering up the Signal Booster.

Disclaimer: The information provided by Wilson Electronics, Inc. is believed to be complete and accurate. However, no responsibility is assumed by Wilson Electronics, Inc. for any business or personal losses arising from its use, or for any infringements of patents or other rights of third parties that may result from its use.

Copyright © 2012 Wilson Electronics, Inc. All rights reserved.

Contact Wilson Electronics Technical Support Team with any questions at 866-294-1660 or email: tech@wilsonelectronics.com. Mon.- Fri. Hours: 7 am to 6 pm MST.

30-Day Money-Back Guarantee

All Wilson Electronics products are protected by Wilson Electronics 30-day money-back guarantee. If for any reason the performance of any product is not acceptable, simply return the product directly to the reseller with a dated proof of purchase.

1-Year Warranty

Wilson Electronics Trucker Spring Mount Dual-Band Cellular Antenna is warranted for one (1) year against defects in workmanship and/or materials. Warranty cases may be resolved by returning the product directly to the reseller with a dated proof of purchase.

Antennas may also be returned directly to the manufacturer at the consumer's expense, with a dated proof of purchase and a Returned Material Authorization (RMA) number supplied by Wilson Electronics. Wilson Electronics shall, at its option, either repair or replace the product. Wilson Electronics will pay for delivery of the repaired or replaced product back to the original consumer within the continental U.S.

This warranty does not apply to any antennas determined by Wilson Electronics to have been subjected to misuse, abuse, neglect, or mishandling that alters or damages physical or electronic properties.

RMA numbers may be obtained by contacting Technical Support at 866-294-1660 or e-mail tech@wilsonelectronics.com or visit www.WilsonElectronics.com.

Antenna Specifications

Part Number	301133 & 308433
Frequency Range	700-800 MHz / 824-894 MHz / 880-960 MHz / 1850-1990 MHz
Impedance	50 ohms
Antenna Gain	3.1 dB 700-800 MHz / 4.1 dBi 824-894 MHz / 2.0 dB 880-960 MHz / 5.1 dBi 1850-1990 MHz
Radiation	Omni
Polarization	Vertical
Ground Plane	Built-in Ground Plane
Connector	FME Female
Material	Whip - Stainless Steel
Coax Cable	RG58 - 13.5 feet / 4.11 meters
Height	21.5 inches including spring mount / 54.61 cm
Mount	Standard CB 3/8 inch x 24 thread



3301 East Deseret Drive, St. George, UT 84790

For additional Technical Support visit www.WilsonElectronics.com

or email at: tech@wilsonelectronics.com

Phone: 866-294-1660 Local: 435-673-5021 Fax: 435-656-2432

www.twitter.com/WilsonCellular www.facebook.com/WilsonCellular